

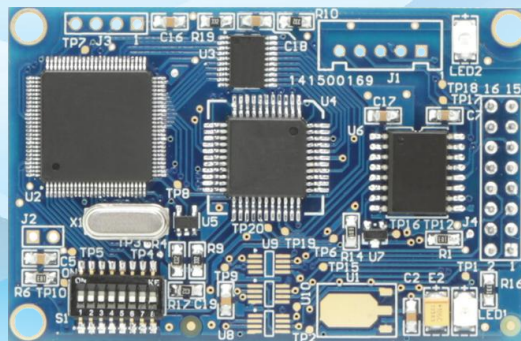

**M0306**  
**MODBUS to DP Built-in Module**  
**User Manual**



Microcyber Corporation

## CAUTION

1. Please don't take off/install components at random.
2. Please check if the power meets the power request in the User Manual.

## Version

V2.0

## Disclaimer of Liability

We have reviewed the contents of this publication to ensure consistency with the hardware and software described. Since variance cannot be precluded entirely, we cannot guarantee full consistency. However, the information in this publication is reviewed regularly and any necessary corrections are included in subsequent editions.

### Microcyber Corporation 2016

The technical data may change at any time.





# TABLE OF CONTENTS

Chapter 1	Overview.....	1
1.1	Module Features.....	1
1.2	Product Development Process.....	3
1.3	Outline Size.....	4
1.4	Module Structure.....	4
Chapter 2	Installation.....	5
2.1	Module External Interface.....	5
2.1.1	Pin Definition and Instruction of User Interface 1 (J4) .....	5
2.1.2	Dial Switch (S1) .....	6
2.2	Module Installation.....	6
Chapter 3	Working Principle.....	8
3.1	Working Mode.....	8
3.2	Modbus Data and PROFIBUS Data Mapping.....	9
3.2.1	Read Coil Input.....	9
3.2.2	Read Register Input.....	10
3.2.3	Write Coil Output.....	10
3.2.4	Write Register Output.....	10
Chapter 4	Module Configuration and Usage.....	12
4.1	Description.....	12
4.2	Parameter Information.....	12
4.2.1	Control parameters of the Whole Device.....	12
4.2.2	Modbus Communication Parameter.....	12
4.2.3	Modbus Input and Output Control Parameter.....	13
4.2.4	PROFIBUS Communication Parameter.....	13
4.2.5	User Parameter.....	16
4.2.6	Serial Port Set DP Address Parameters.....	17
4.2.7	Restore factory settings.....	18
4.2.8	Generate GSD Files.....	18
4.3	Module Usage.....	18
4.3.1	Set Slave Station Address.....	18
4.3.2	Device Configuration.....	19
Chapter 5	Modbus 通信异常诊断.....	23
5.1	Device Online Monitoring.....	23
5.2	Monitoring Module Information.....	24
5.3	DP Slave Diagnosis.....	25
5.4	Diagnosis Information Analysis.....	26
Chapter 6	GSD file, ID certification test.....	29
6.1	GSD file、ID and certification test.....	29
6.1.1	GSD file (Electronic Data Sheet) .....	29
6.1.2	ID (Ident Number) .....	30
6.1.3	Certification Test.....	30
6.2	User product GSD File and ID.....	30
Chapter 7	Maintenance.....	30
Chapter 8	Technical Specification.....	32
8.1	Basic Parameter.....	32
8.2	Support Modbus Function Code.....	32
Appendix 1	GSD File Example.....	33
Appendix 2	Model Selection.....	34

# Chapter 1 OVERVIEW

M0306 Modbus to DP built-in module is one of the Microcyber M-series embedded modules developed by Microcyber Corporation. This series of embedded modules have features like same size, same interface, easy to upgrade, easy configuration and so on, it is the ideal choice for users to quickly develop the fieldbus equipment.

By embedding the M0306 into the users' equipment's with Modbus-RTU communication capabilities, the user equipment can be changed to Profibus DP slave station.

User can quickly achieve Profibus DP, FF, HART & etc. equipment by replacing other modules of M series.

This product has four types based on MCU power supply voltage and whether user interface 2 is available. Please check detailed in **Error! Reference source not found.** M0306 Modbus to DP built-in module is shown as figure Figure 1.1:

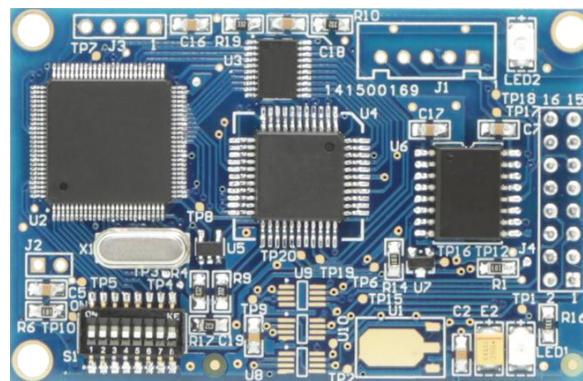

Figure 1.1 M0306 Modbus to DP Built-in Module

## 1.1 Module Features

- 1) **Short development period** : The user doesn't need to understand PROFIBUS developing technology, doesn't need to purchase PROFIBUS development system, also doesn't need to compile GSD file, PROFIBUS product with intellectual property will be developed in short time;
- 2) **Same size**: Microcyber M-series embedded modules have the same size, 65mm (length) \*42mm (width) .
- 3) **Same interface**: Microcyber M-series embedded modules adopt 2.54 spacing 16 pin connector, with compatible function.
- 4) **Easy to upgrade**: Replacement of Microcyber M-series different embedded modules can achieve different protocols of the device.
- 5) **Flexible configuration**: Users can use Microcyber configuration tool to configure it, which is easy and



convenient to operate

- 6) **Simple application** : MCU of user's product read (write) input/output data into communication module by serial port. The communication module automatically transfers them into the communication between PROFIBUS-DP data and PROFIBUS master station;
- 7) **Wide application** : Widely used onto all kinds of products, such as transducer, motor startup protection device, smart high-low-voltage electrical appliance, power measurement device, various transmitters, smart field measurement equipment, and instrumentation, etc.
- 8) **Provide based on OEM** : The user has independent intellectual property rights, brand and trademark registration right.

## 1.2 Product Development Process

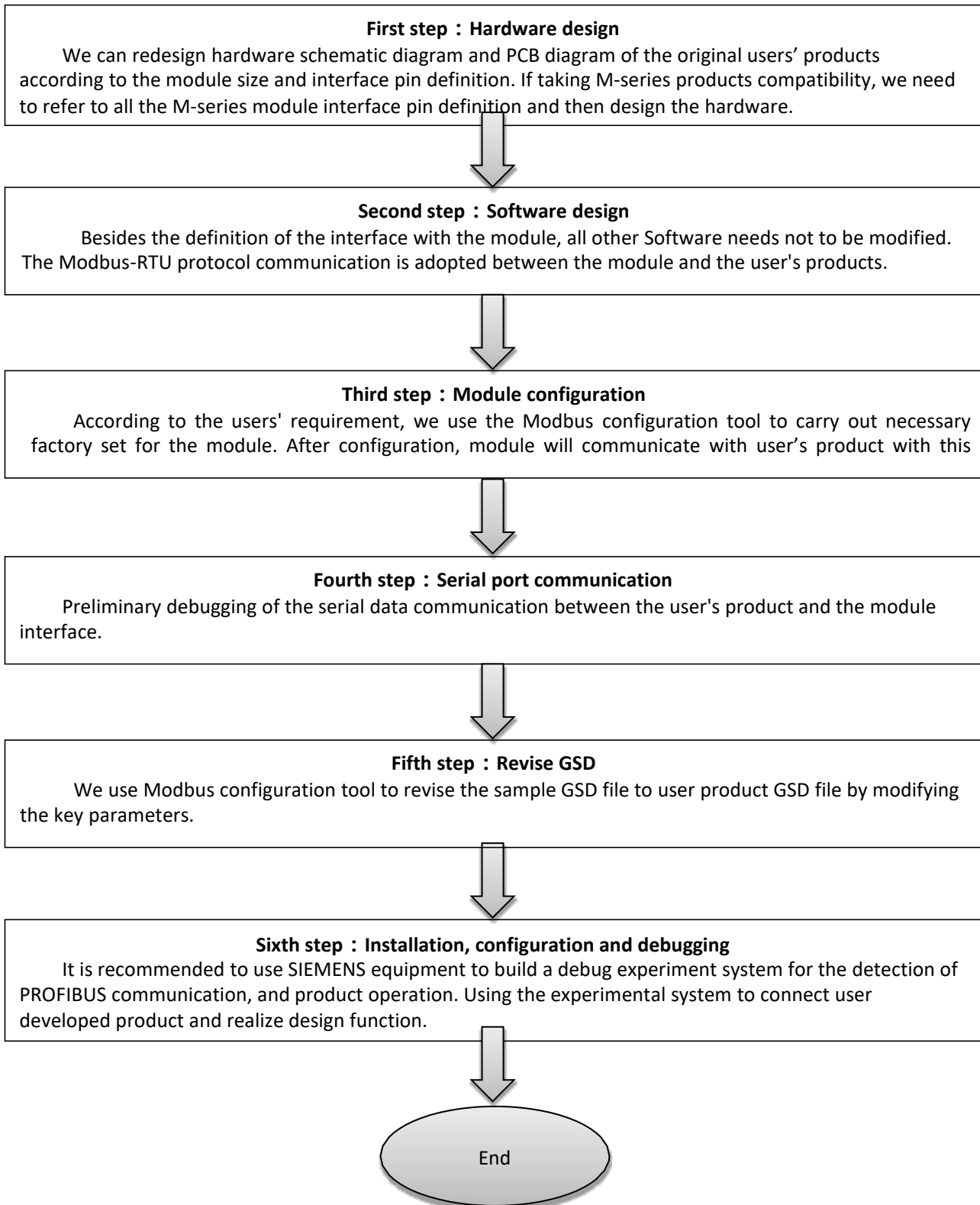

### 1.3 Outline Size

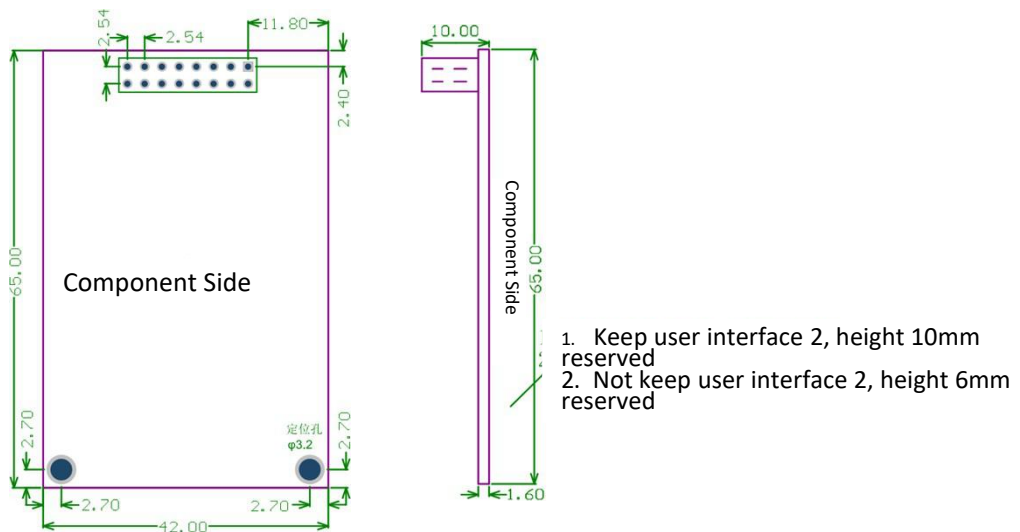

Figure 1.2 Outline Size (unit: mm)

### 1.4 Module Structure

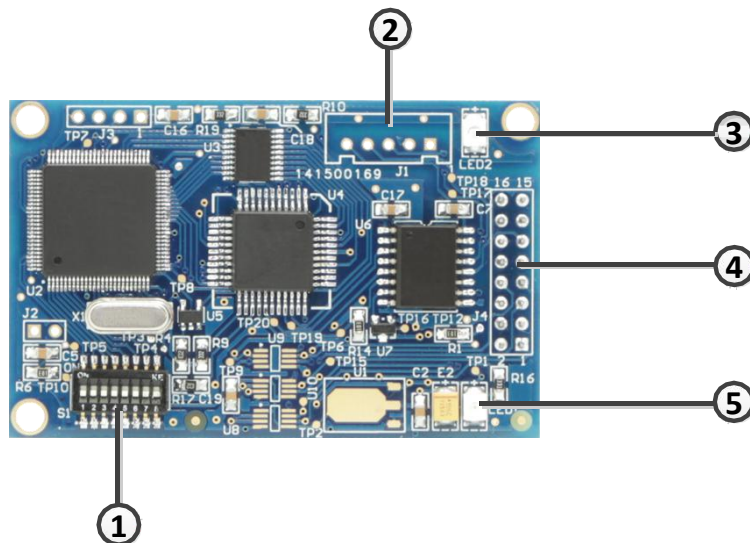

Figure 1. Module Structure

1	Dial switch (S1)	2	User interface 2 (J1)	3	Modbus communication indication (LED2)
4	User interface 1 (J4)	5	DP communication indication (LED1)		

# Chapter 2 INSTALLATION

## 2.1 Module External Interface

### 2.1.1 Pin Definition and Instruction of User Interface 1 ( J4 )

The user interface provides the module with one signal isolated DC power supply, serial interface between the two boards, as well as indicator lights and other functions. The specific description is shown in table Table 2.1.

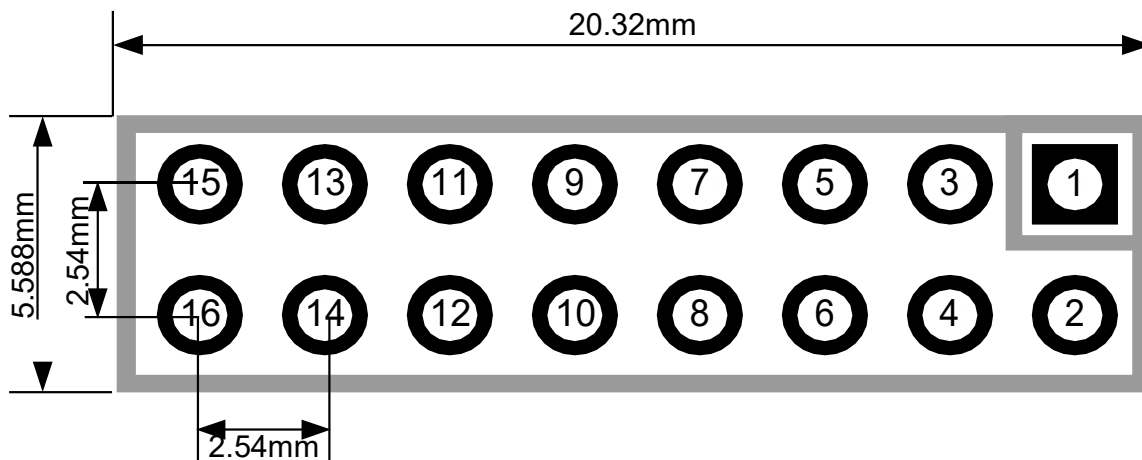

Figure 2.1 Pin Definition and Outline Size of User Interface

As shown in figureFigure 2.1, user interface 1 uses 16-pin connector, specific pins are defined as follows:

Table 2.1 User Interface Pin Definition

Pin	I/O	Description	Pin	I/O	Description
1	I	VCC (5.0V / 3.3V DC)	2	O	VCC grounding
3	I	CPU Reset, Low Valid	4	I/O	Reserved
5	O	CPU serial data transmission	6	I/O	Reserved
7	I/O	Reserved	8	I	CPU serial data acceptance
9	O	Connect No.4 pin of PROFIBUS DP D type socket	10	O	DP communication state indication
11	I/O	Connect No.3 pin of PROFIBUS DP D type socket	12	I/O	Connect No.8 pin of PROFIBUS DP D type socket
13	I/O	Reserved	14	I/O	Reserved
15	I	5V isolation power supply	16	O	0V (isolation power supply grounding, isolated with GND)



## 2.1.2 Dial Switch ( S1 )

。 The dial switch contains PROFIBUS DP slave station address setting and working mode selection function.

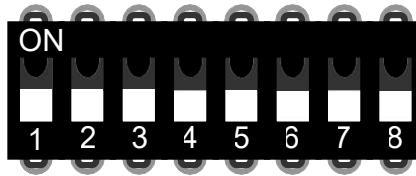

Figure 2.2 Dial Switch S1

Table 2.2 Dial Switch S1 Function Description

No.	Name	Description
1	1	If ON, address+1, if not, address+0.
2	2	If ON, address +2, if not, address +0.
3	4	If ON, address +4, if not, address +0.
4	8	If ON, address +8, if not, address +0.
5	16	If ON, address +16, if not, address +0.
6	32	If ON, address +32, if not, address +0.
7	64	If ON, address +64, if not, address +0.
8	M	M0306 working mode setting, ON is configuration mode, and OFF is normal working mode.

## 2.2 Module Installation

M0306 has three  $\Phi 3$  location hole and it can be fixed to user board with three hexagonal prisms (height 11mm) to fix.

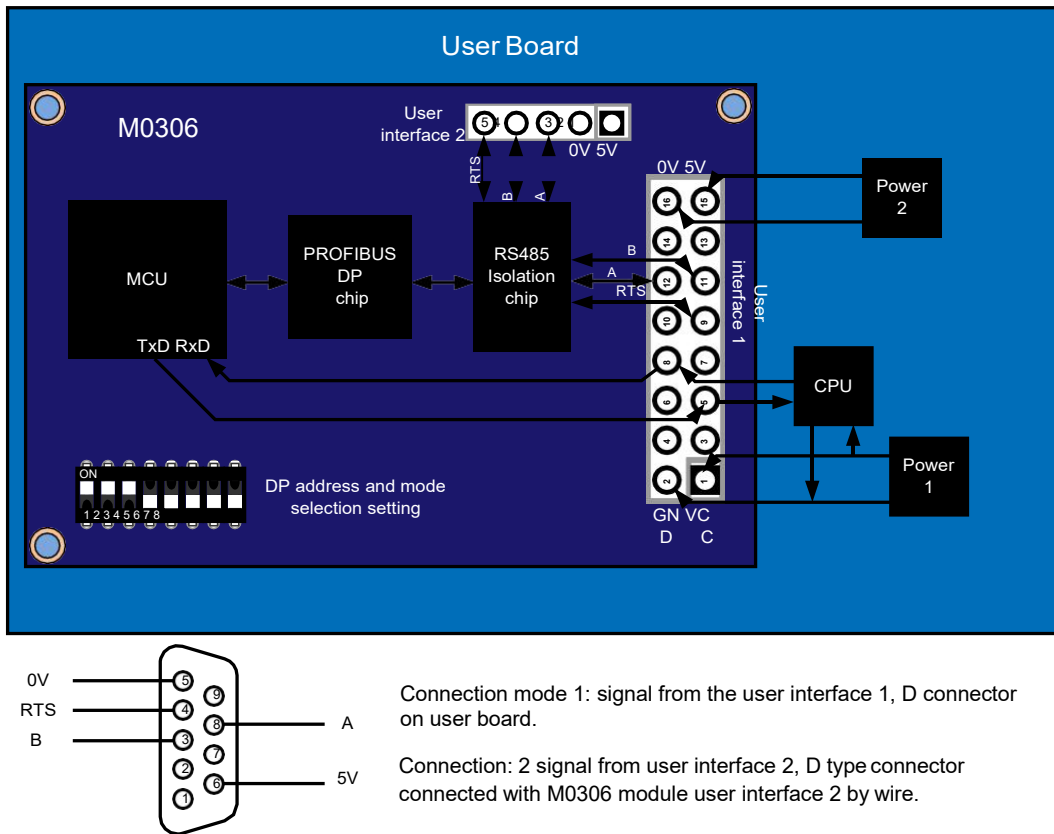

Figure 2.3 Module Installation

## Chapter 3 WORKING PRINCIPLE

M0306 supports one to one embedded connection with the RTU Modbus user board. The main function is to connect the user board to the PROFIBUS network, making it become PROFIBUS DP slave device. M0306 system connection diagram is shown in Figure 3.1:

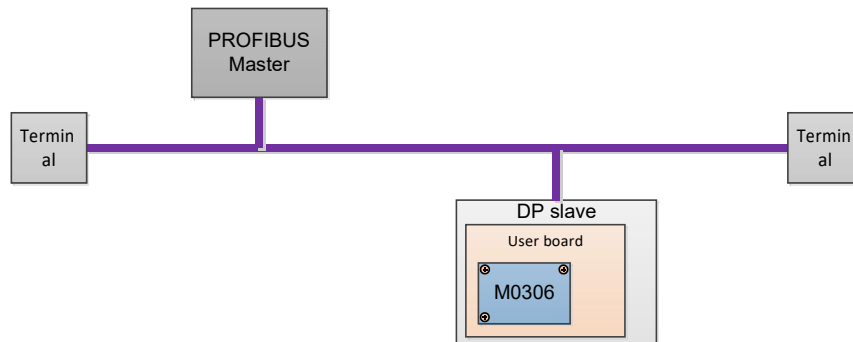

Figure 3.1 M0306 System Connection Diagram

M0306 module can complete the protocol conversion between PROFIBUS and Modbus, to achieve mapping and transparent transmission between user board Modbus input and output data and PROFIBUS master control system input and output data. The working principle of M0306 is shown in Figure 3.2.

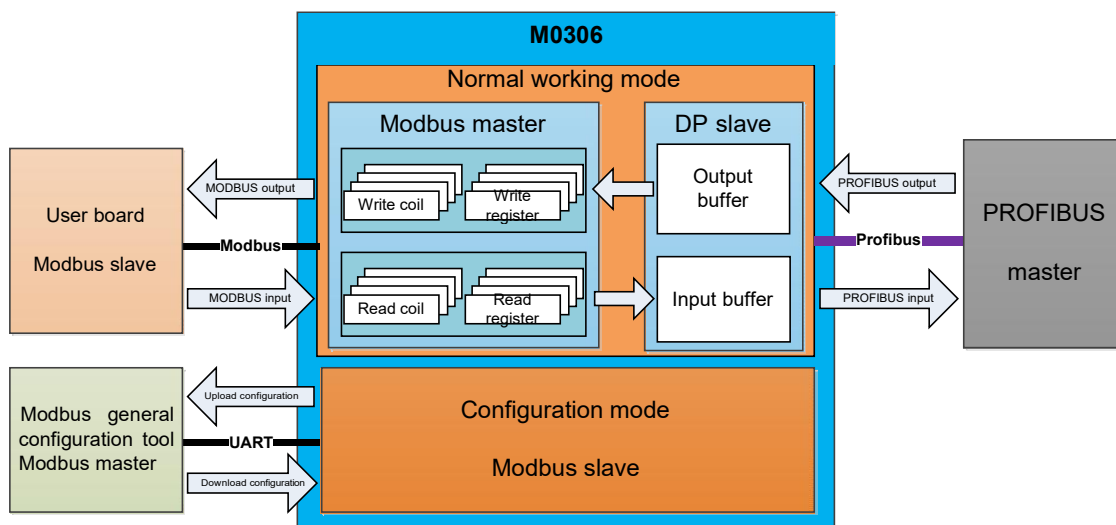

Figure 3.2 M0306 Working Principle

### 3.1 Working Mode

M0306 supports two modes of operation: configuration mode and normal operation mode, which can be switched in real-time according to the dial switch.

When M0306 works in configuration mode, M0306 is used as the Modbus slave station, while the Modbus general configuration tool is used as the Modbus master station. Through the Modbus general configuration tool, besides the configuration of basic information such as manufacturer ID, device ID and device address sources, the

main function is the configuration of read-write user board Modbus input and output data's Modbus command queue parameter information, such as which MODBUS function code are used by parameters to read and write, what the register address is and so on. After the configuration, the information will be downloaded to the M0306. Under normal operating mode, M0306 is master station in Modbus side, the user board is Modbus slave station. In accordance with configured parameters and mechanisms, M0306 circularly sends Modbus command queue to the user board to read and write user board Modbus input and output data. M0306 is DP slave station at the PROFIBUS terminal, conducting real-time PROFIBUS input and output data exchange with PROFIBUS master control system.

### 3.2 Modbus Data and PROFIBUS Data Mapping

The main function of M0306 module is to realize the mapping and transparent transmission between user board Modbus input and output data and PROFIBUS master control system input and output data. The specific data mapping relation is shown in Figure 3.3:

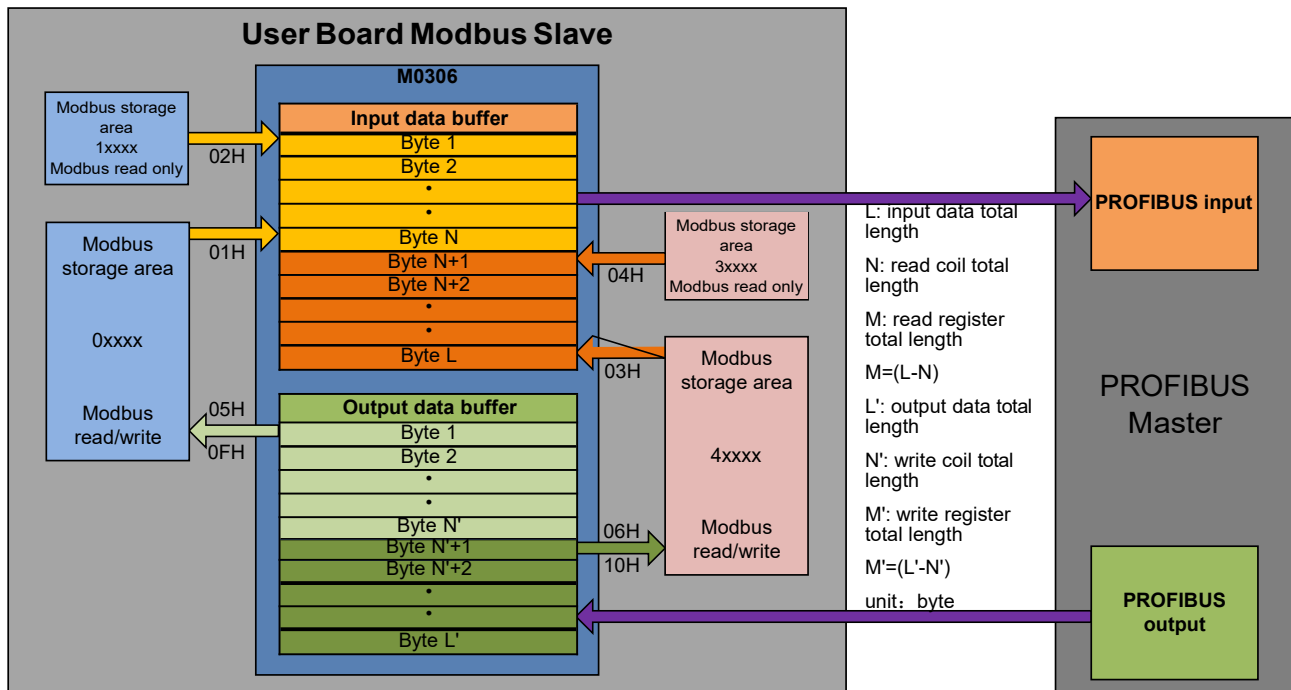

Figure 3.3 Modbus and PROFIBUS I/O Data Mapping Relation

During the usage of module, user can realize the I/O data exchange between module and user board through the specific configuration of the Modbus command. the I/O data store address correspondence in PROFIBUS master system is related with "I/O configuration identifier", and also the specific type of PROFIBUS master station system. Specific module configuration and application methods will be introduced in the fourth chapter. The following is example of SIEMENS S7-300 series PLC master system to introduce the I/O data address mapping between user board and the PROFIBUS master system.

### 3.2.1 Read Coil Input

As shown in Figure 3.4, M0306 read 20 coils status data from user board's digital storage area (0xxxx/1xxxx) via 01H or 02H command. The 1-8 coil status data is saved in 0 address byte of input data buffer, the 9-16 is in 1 address byte, the 17-20 is in 2 address byte. Finally send the 3 bytes input data to PROFIBUS master control system, corresponding to IB0..IB2 address bytes in PROFIBUS input area.

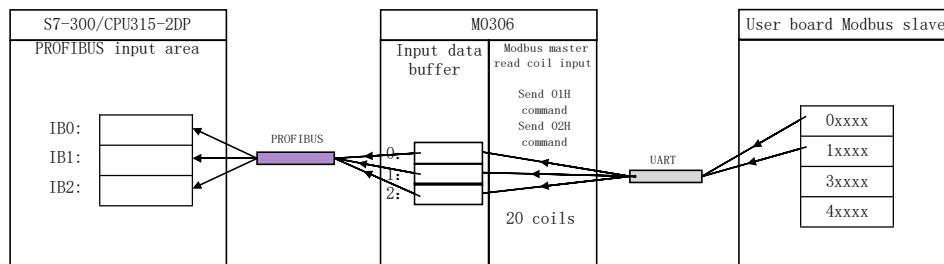

Figure 3.4 Read coil input data address mapping and transmission

### 3.2.2 Read Register Input

As shown in figureFigure 3.5, M0306 read 3 words analog data from user board's analog storage area (3xxxx/4xxxx) via 03H or 04H command. The first analog data is saved in 3、4 address byte of input data buffer, the second is in 5、6 address byte, the third is in 7、8 address byte. Finally send the 3 words (6 bytes) analog input to PROFIBUS master control system, corresponding to PROFIBUS IB256..IB261 address bytes in the input area.

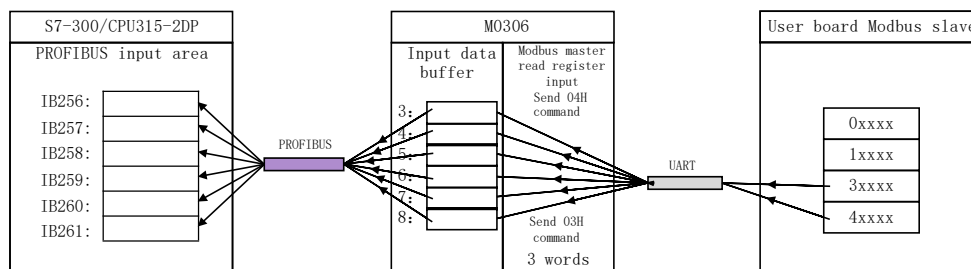

Figure 3.5 Read register input data address mapping and transmission

### 3.2.3 Write Coil Output

As shown in figureFigure 3.6, QB0..QB2 is PROFIBUS output address for 20 coils (3 bytes) digital output assigned by PROFIBUS master control system. M0306 will save the 3 bytes output data in 0.2 address byte of output data buffer, and then send them to user board's digital storage area(0xxxx) via 05H or 0FH command.

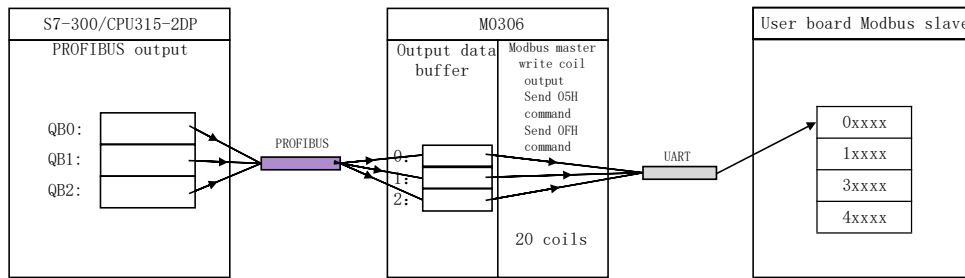

Figure 3.6 Write coil output data address mapping and transmission

### 3.2.4 Write Register Output

As shown in Figure 3.7, QB256..QB261 is PROFIBUS output address for 3 words (6 bytes) analog output data assigned by PROFIBUS master control system. M0306 will save the 6 bytes output data in 3.8 address byte of output data buffer, and then send them to analog storage area (4xxxx) of user board via 06H or 10H command.

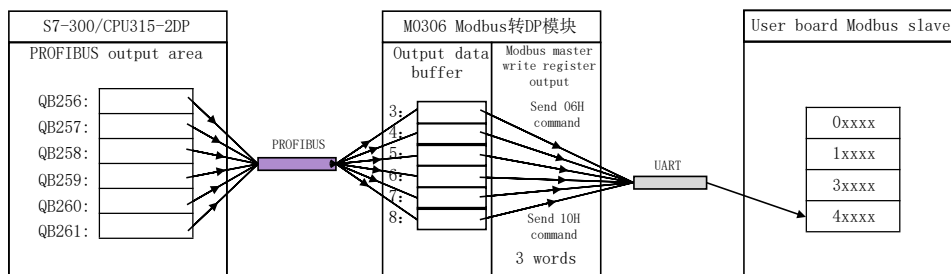

Figure 3.7 Write register output data address mapping and transmission



# Chapter 4 MODULE CONFIGURATION AND USAGE

## 4.1 Description

Before starting the normal operation mode, user needs to configure M0306 by configuration mode.

The method is as follows:

- 1) Set module dial switch S1.8 bit to ON, making the module power on;
- 2) Through the TTL to the serial port device, connect the module to computer serial port;
- 3) Install and open the Modbus general configuration tool, add the device by adding the serial port;
- 4) After scanning the device, the basic parameters of the device information will be read to the general configuration tool. Next, the user can refer to the specific needs of the configuration parameters to modify module;
- 5) Save the configuration. User can save a configuration file via configuration parameters saving function after configuration parameters, download the saved configuration file before batch configuration of various modules, with other working parameter modules for batch download.

## 4.2 Parameter Information

### 4.2.1 Control parameters of the Whole Device

Table 4.1 Control parameters of the Whole Device

Parameter name	Description	Default
Protocol	M0306 module internal protocol (read only) .	0x0306
Parameter data configuration sign	The effectiveness sign of the configuration parameters, indicating the state of the internal parameters of the module. 0x00: invalid (module current parameter configuration is invalid) 0xFEDCCDEF: valid (module current parameter configuration is valid, that is, the current configuration parameters of the enable module)	0

### 4.2.2 Modbus Communication Parameter

Modbus communication parameters are the most basic configuration parameters between the module and the user board. Only when these parameters are configured properly, can the module communicate with the user board correctly.

Table 4.2 Modbus Communication Parameter

Parameter name	Description	Default
Baud rate	0: 2400    1: 4800    2: 9600    3: 14400    4: 19200	4
Data bits	0: 8 (read only)	0
Verification mode	0: None    1: Even    2: Odd	1



Interface type	0: TTL    1: RS232 (reserved)    2: RS485 (reserved)	0
Stop bits	0: One Stop Bit    1: Two Stop Bits (read only: automatically set according to the verification mode)	0
Slave station	User board Modbus slave station communication address, address range: 1~255	1
CRC check order	CRC check order 0: Normal (low-high) 1: Swapped (high-low)	0
Timeout	Timeout waiting time, range: 300ms~1000ms	300
Number of retry times	timeout, number of times, range: 1~10 (the usage of the loop Modbus command communication process)	3

### 4.2.3 Modbus Input and Output Control Parameter

In the normal mode of operation, Modbus terminal of the M0306 is the master, which can read and write user board input and output data by sending the Modbus command to the user board. Configuration of the Modbus command related control parameters that need to be configured can be configured by the Modbus general configuration tool.

Table 4.3 Modbus Input and Output Control Parameter

Parameter name	Description	Default
Modbus command quantity	The number of Modbus commands with the user board loop communication N (0~20)	1
Total length of input data	User board actual input data total length (0~244 bytes)	1
Total length of output data	User board actual output data total length (0~244 bytes)	0
Command 1 function code	Modbus command function code (01H、02H、03H、04H、05H、06H、0FH、10H)	01H
Command 1 register address	Modbus operation valid register address (0~65535)	1
Command 1 data quantity	Operating coil or register number (coil: 1~1952 register: 1~122)	8
Command 1 data update mode	Read command: No; write command: always write (0) / change write (1)	0
Command 2 function code	Modbus command function code (01H、02H、03H、04H、05H、06H、0FH、10H)	X
Command 2 register address	Modbus operation valid register address (0~65535)	0
Command 2 data quantity	Operating coil or register number (coil: 1~1952 register: 1~122)	1
Command 2 data update mode	Read command: No; write command: always write (0) / change write (1)	0
...	...	
Command N function code	Modbus command function code (01H、02H、03H、04H、05H、06H、0FH、10H)	X
Command N register address	Modbus operation valid register address	0
Command N data quantity	Operating coil or register number (coil: 1~1952 register: 1~122)	1
Command N data update mode	Read command: No; write command: always write (0) / change write (1)	0

Parameter description:





Modbus general configuration tool divides Modbus command into four groups: read coil, read register, write coil, write register. User only need to add the Modbus command and set the relevant parameters, other parameters are automatically calculated by the configuration tool software.

### 4.2.4 PROFIBUS Communication Parameter

In the normal working mode, PROFIBUS terminal of M0306 module is slave station, which conduct cycle PROFIBUS data communication with PROFIBUS master station control system. Required parameters include the device ID number, I/O configuration data length and specific I/O configuration data content.

Table 4.4 PROFIBUS Communication Parameter

Parameter name	Description	Default
Device ID	To develop DP equipment, the first is to become member of the PI organization, and then to apply device ID. nonmembers are not allowed to apply it. Device ID is mainly used in the device description file.	0x0FC5
I/O configuration data length	Total number of input and output data identifiers N (0~20)	1
I/O configuration data 1	Identifiers value (refer to Table 4.5)	0x10
...	Ditto	0
I/O configuration data N	Ditto	0

Parameter description:

Device ID need to be manually added by the user.

I/O configuration data length and I/O configuration data values are automatically calculated and generated via Modbus general configuration tool based on Modbus command parameter information configured by user in the 4.2.3. At the same time, in the configuration tool, each I/O configuration data item has data continuity options for the user to choose. Please refer to the "code" and "description" in the following table for I/O configuration data content and meaning.

Table 4.5 I/O Configuration Data Code

Code	Description	Code	Description
	byte input, Byte complete		byte input, All input/output
0x10	1 byte input, Byte complete	0x90	1 byte input, All input/output complete
0x11	2 byte input, Byte complete	0x91	2 byte input, All input/output complete
0x12	3 byte input, Byte complete	0x92	3 byte input, All input/output complete
0x13	4 byte input, Byte complete	0x93	4 byte input, All input/output complete
0x14	5 byte input, Byte complete	0x94	5 byte input, All input/output complete
0x15	6 byte input, Byte complete	0x95	6 byte input, All input/output complete
0x16	7 byte input, Byte complete	0x96	7 byte input, All input/output complete
0x17	8 byte input, Byte complete	0x97	8 byte input, All input/output complete
0x18	9 byte input, Byte complete	0x98	9 byte input, All input/output complete
0x19	10 byte input, Byte complete	0x99	10 byte input, All input/output



Code	Description	Code	Description
<b>0x1A</b>	11 byte input, Byte complete	<b>0x9A</b>	11 byte input, All input/output
<b>0x1B</b>	12 byte input, Byte complete	<b>0x9B</b>	12 byte input, All input/output complete
<b>0x1C</b>	13 byte input, Byte complete	<b>0x9C</b>	13 byte input, All input/output complete
<b>0x1D</b>	14 byte input, Byte complete	<b>0x9D</b>	14 byte input, All input/output complete
<b>0x1E</b>	15 byte input, Byte complete	<b>0x9E</b>	15 byte input, All input/output complete
<b>0x1F</b>	16 byte input, Byte complete	<b>0x9F</b>	16 byte input, All input/output complete
	<b>byte output, Byte complete</b>		<b>byte output, All input/output complete</b>
<b>0x20</b>	1 byte output, Byte complete	<b>0xA0</b>	1 byte output, All input/output complete
<b>0x21</b>	2 byte output, Byte complete	<b>0xA1</b>	2 byte output, All input/output complete
<b>0x22</b>	3 byte output, Byte complete	<b>0xA2</b>	3 byte output, All input/output complete
<b>0x23</b>	4 byte output, Byte complete	<b>0xA3</b>	4 byte output, All input/output complete
<b>0x24</b>	5 byte output, Byte complete	<b>0xA4</b>	5 byte output, All input/output complete
<b>0x25</b>	6 byte output, Byte complete	<b>0xA5</b>	6 byte output, All input/output complete
<b>0x26</b>	7 byte output, Byte complete	<b>0xA6</b>	7 byte output, All input/output complete
<b>0x27</b>	8 byte output, Byte complete	<b>0xA7</b>	8 byte output, All input/output complete
<b>0x28</b>	9 byte output, Byte complete	<b>0xA8</b>	9 byte output, All input/output complete
<b>0x29</b>	10 byte output, Byte complete	<b>0xA9</b>	10 byte output, All input/output complete
<b>0x2A</b>	11 byte output, Byte complete	<b>0xAA</b>	11 byte output, All input/output complete
<b>0x2B</b>	12 byte output, Byte complete	<b>0xAB</b>	12 byte output, All input/output complete
<b>0x2C</b>	13 byte output, Byte complete	<b>0xAC</b>	13 byte output, All input/output complete
<b>0x2D</b>	14 byte output, Byte complete	<b>0xAD</b>	14 byte output, All input/output complete
<b>0x2E</b>	15 byte output, Byte complete	<b>0xAE</b>	15 byte output, All input/output complete
<b>0x2F</b>	16 byte output, Byte complete	<b>0xAF</b>	16 byte output, All input/output complete
	<b>word input, Word complete</b>		<b>word input, All input/output complete</b>
<b>0x50</b>	1 word input, Word complete	<b>0xD0</b>	1 word input, All input/output complete
<b>0x51</b>	2 word input, Word complete	<b>0xD1</b>	2 word input, All input/output complete
<b>0x52</b>	3 word input, Word complete	<b>0xD2</b>	3 word input, All input/output complete
<b>0x53</b>	4 word input, Word complete	<b>0xD3</b>	4 word input, All input/output complete
<b>0x54</b>	5 word input, Word complete	<b>0xD4</b>	5 word input, All input/output complete
<b>0x55</b>	6 word input, Word complete	<b>0xD5</b>	6 word input, All input/output complete
<b>0x56</b>	7 word input, Word complete	<b>0xD6</b>	7 word input, All input/output complete
<b>0x57</b>	8 word input, Word complete	<b>0xD7</b>	8 word input, All input/output complete
<b>0x58</b>	9 word input, Word complete	<b>0xD8</b>	9 word input, All input/output complete
<b>0x59</b>	10 word input, Word complete	<b>0xD9</b>	10 word input, All input/output complete
<b>0x5A</b>	11 word input, Word complete	<b>0xDA</b>	11 word input, All input/output complete
<b>0x5B</b>	12 word input, Word complete	<b>0xDB</b>	12 word input, All input/output complete
<b>0x5C</b>	13 word input, Word complete	<b>0xDC</b>	13 word input, All input/output complete
<b>0x5D</b>	14 word input, Word complete	<b>0xDD</b>	14 word input, All input/output complete
<b>0x5E</b>	15 word input, Word complete	<b>0xDE</b>	15 word input, All input/output complete



Code	Description	Code	Description
0x5F	16 word input, Word complete	0xDF	16 word input, All input/output complete
	word output, Word complete		word output, All input/output complete
0x60	1 word output, Word complete	0xE0	1 word output, All input/output complete
0x61	2 word output, Word complete	0xE1	2 word output, All input/output complete
0x62	3 word output, Word complete	0xE2	3 word output, All input/output complete
0x63	4 word output, Word complete	0xE3	4 word output, All input/output complete
0x64	5 word output, Word complete	0xE4	5 word output, All input/output complete
0x65	6 word output, Word complete	0xE5	6 word output, All input/output complete
0x66	7 word output, Word complete	0xE6	7 word output, All input/output complete
0x67	8 word output, Word complete	0xE7	8 word output, All input/output complete
0x68	9 word output, Word complete	0xE8	9 word output, All input/output complete
0x69	10 word output, Word complete	0xE9	10 word output, All input/output complete
0x6A	11 word output, Word complete	0xEA	11 word output, All input/output complete
0x6B	12 word output, Word complete	0xEB	12 word output, All input/output complete
0x6C	13 word output, Word complete	0xEC	13 word output, All input/output complete
0x6D	14 word output, Word complete	0xED	14 word output, All input/output complete
0x6E	15 word output, Word complete	0xEE	15 word output, All input/output complete
0x6F	16 word output, Word complete	0xEF	16 word output, All input/output complete

Continuity is the representation of the continuity of the transmission data, that is, whether a single word or a byte or various words or bytes together can be used to represent a single data.

- 1) Single byte or word's data has continuity (continuity is "single"), corresponding to "Byte complete and Word complete" in table above;
- 2) Whole module's data has continuity (continuity is "complete"), corresponding to "All input/output complete" in table above.

### 4.2.5 User Parameter

For industrial field device, users often need to set some parameters according to the field application. Some of these parameters do not need to be changed in real time during operation, such as transducer's current upper limit protection and alarm value, temperature sensor's measurement temperature range and so on. If these parameters are used for PROFIBUS master station I/O output, they will occupy PROFIBUS master station I/O resources and periodic polling PROFIBUS slave station's time resources. If these parameters are processed as "user parameters", it will shorten the communication time of PROFIBUS master station, reduce the length of communication message and improve the efficiency of bus communication. Using the "user parameters" technology, user only need to make the parameter selection in the main station configuration. When the master station is connected with the slave station, the parameters can be transmitted to the slave station once. And slave station can process



parameterization on slave station with the user selected parameters (initialization, parameter setting).

Table 4.6 User Parameter

Parameter name	Description	Default
Modbus command quantity	Configure user parameter Modbus command quantity N (0~10)	0
Parameter length	User parameter total length (0~200 bytes)	0
Command 1 function code	Modbus command function code (05H、06H、0FH、10H)	06H
Command 1 register address	Modbus operation valid register address (0~65535)	0
Command 1 data quantity	Operation coil or register quantity (coil: 1~1952 register: 1~122)	1
Command 1 data	Modbus command 1 operation data (Hex)	NULL
Command 2 function code	Modbus command function code (05H、06H、0FH、10H)	06H
Command 2 register address	Modbus operation valid register address (0~65535)	0
Command 2 data quantity	Operation coil or register quantity (coil: 1~1952 register: 1~122)	1
Command 2 data	Modbus command operation data (Hex)	NULL
...	...	0
Command N function code	Modbus command function code (05H、06H、0FH、10H)	06H
Command N register address	Modbus operation valid register address (0~65535)	0
Command N data quantity	Operating coil or register quantity (coil: 1~1952 register: 1~122)	1
Command N data	Modbus command N operation data (Hex)	NULL

When user enables this function, user parameter data will be written to the device GSD file, as shown in following example:

Max\_User\_Prm\_Data\_Len=8 (max user parameter length (byte))

Ext\_User\_Prm\_Data\_Const(0)=0x00,0x00,0x00,0x01,0x02,0x03,0x04,0x05 (user parameter)

Notice:

- 1) The first 3 bytes (red) in user parameters are specific parameters for DP-V1, reserved in the GSD files. In this case, the maximum user parameter length should be user parameter total length plus three. These parameters are automatically calculated and processed by general configuration tool.
- 2) When using 06H or 10H Modbus Command, operating data (user parameter) using two bytes (one word) to represent one register value (first higher, then lower), for example: When using 10H command to write two registers, with value 0x11 and 0x22, then it should be wrote like the following format: 0x00, 0x11, 0x00, 0x22 (with “,” in each byte);
- 3) When using 05H command, the operation data (user parameters) use one byte to represent one coil state value. 0xFF means that coil is set on 1, and 0x00 means that coil is set on 0. When using 0FH command, one byte represents eight coils' state.
- 4) When using APC3 chip M0306, DP bus baud rate is set higher than 9600 bps if user parameter total length is over 120 bytes. If any special requirements, please contact us for the same type VPC3 chip M0306.



### 4.2.6 Serial Port Set DP Address Parameters

M0306 module supports two ways to set the DP from the station address, one is through the code switch S1.1~S1.7 bit set, the other can be obtained through the serial port from the user board. When the serial set DP address function is enabled, user can set Modbus command parameters for DP address data, including DP address 's Modbus command function code and operand register address. Since the default operation quantity is 1, that is, through user configured function code reading register value (2 bytes) from the user board's target address, users should also set to save the high/low DP bytes of address data. In this case, under normal working mode, when M0306 is power on, it will, through serial port, send Modbus command to get DP slave station address data preserved in the user board. This function's enabling and the corresponding parameters' configuration can be configured by the Modbus general configuration tool.

Table 4.7 Serial Port Set DP Address Parameters

Parameter name	Description	Default
Serial port set DP address enabling	Enable / disable serial port set address. 0: disable (DP slave station address is obtained from the S1 dial switch, when the address is higher than 125 , set the maximum value 125) 1: enable ( DP slave station address is got from user board, valid range 1~125)	0
Modbus command function code	Get DP address Modbus command function code. It's effective only when the serial port's setting address function enabled. 0: 03H 1: 04H	0
Modbus register address	Get address command operation's register address (0~65535), It's effective only when the serial port's setting address function enabled.	0
Address data valid bit identifier	An effective bit identifier for DP address data saved in the user board. It's effective only when the serial port's setting address function enabled. 0: Take data's low byte value as DP slave address 1: Take data's high byte value as DP slave address	0

### 4.2.7 Restore factory settings

M0306 module supports restoring the factory settings via software. In the configuration mode, M0306 module will conduct real-time detection of the parameter settings and the implementation of corresponding operation. These parameters can be configured through the Modbus general configuration tool.

Table 4.8 Restore factory settings

Parameter name	Description	Default
Restore factory settings	Software restoring factory settings sign. 0: not restore 1: restore (module restore factory parameter settings, parameter configuration invalid)	0

### 4.2.8 Generate GSD Files

Through the Modbus configuration tool, user can configure some of the basic information in the GSD file and



generate user proprietary GSD file. If the user is not satisfied with the generated GSD file, he can refer to the GSD specification or special tools to modify the generated GSD file. Please see GSD example on appendix0.

Each DP slave device has a device icon file, using the Windows Bitmap format (.bmp), with length 70\* width 40 pixels. User can refer to the specifications to make an device icon file belonging to their own products. Please attention that the prefix name should be the same with GSD file's.

## 4.3 Module Usage

When the configuration is completed, it switches back to normal working mode. It can be embedded into users' products to form Profibus DP slave station device.

### 4.3.1 Set Slave Station Address

It's introduced already that M0306 supports two kinds of methods to set DP slave address. Please see details in 4.2.6.

### 4.3.2 Device Configuration

#### 4.3.2.1 GSD File Instruction

DP device must have manufacturer GSD file, which is the GSD file generated in above content. User need to use this GSD file to configure the DP slave station device, after which it can start cyclic data exchange service with class one master station.

#### 4.3.2.2 Install GSD File

- 1) Take Siemens STEP 7 Software as an example, choose any project, open hardware configuration, choose "Options→Install GSD File...", and it will open the GSD file window, as shown in figure Figure 4.1:

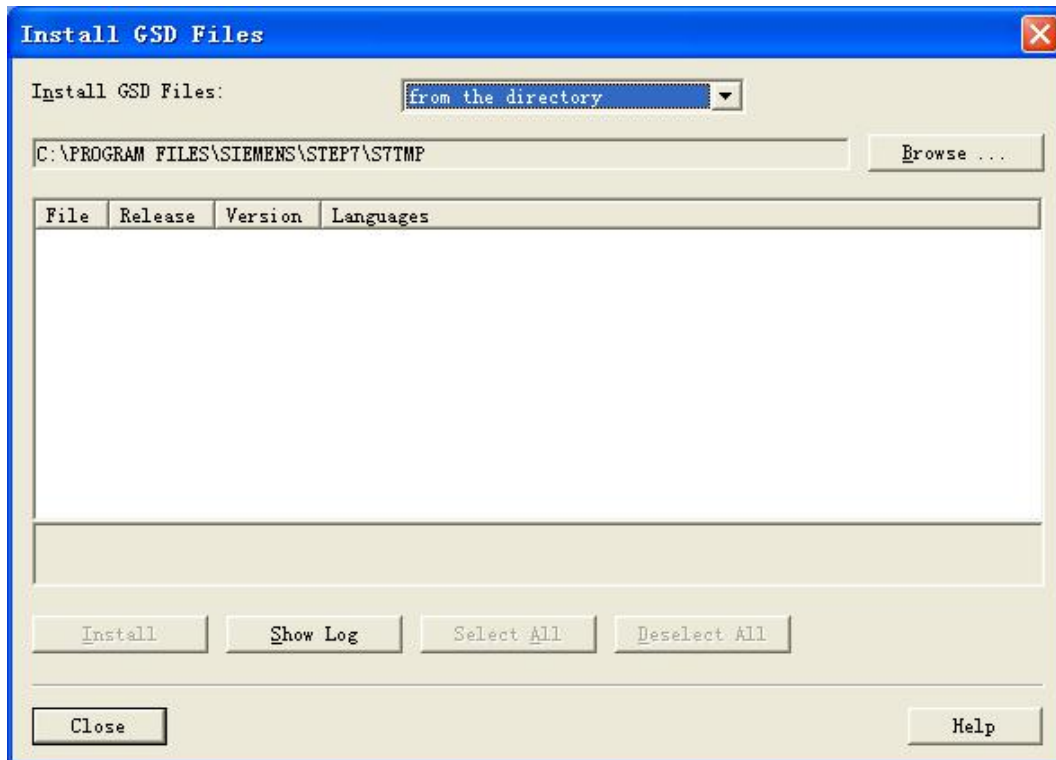

Figure 4.1 GSD file window

- 2) Click "Browse..." and choose the path for GSD file. It will list all the GSD files in the present path, choose the GSD file MCYB0FC5.gsd and click "Install". Keep clicking "Yes", until figure Figure 4.2 is shown:

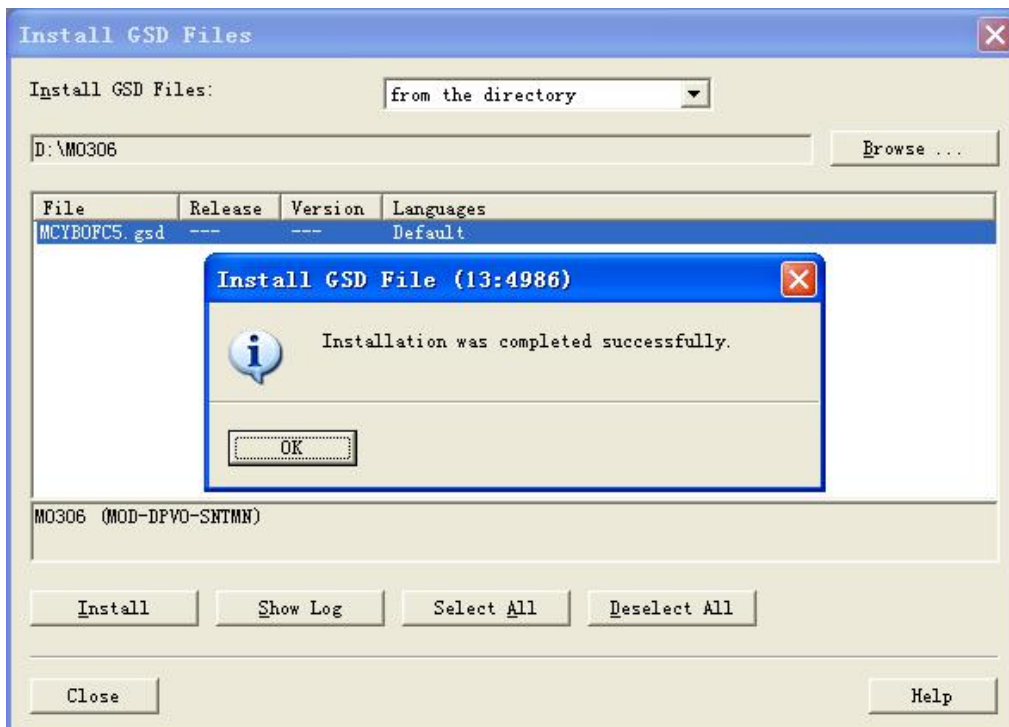

Figure 4.2 Successful Installation



### 4.3.2.3 Use GSD file

- 1) After successful installation for GSD, the module shall appear in the tree list at the right side of the hardware configuration window, as shown in figure Figure 4.3:

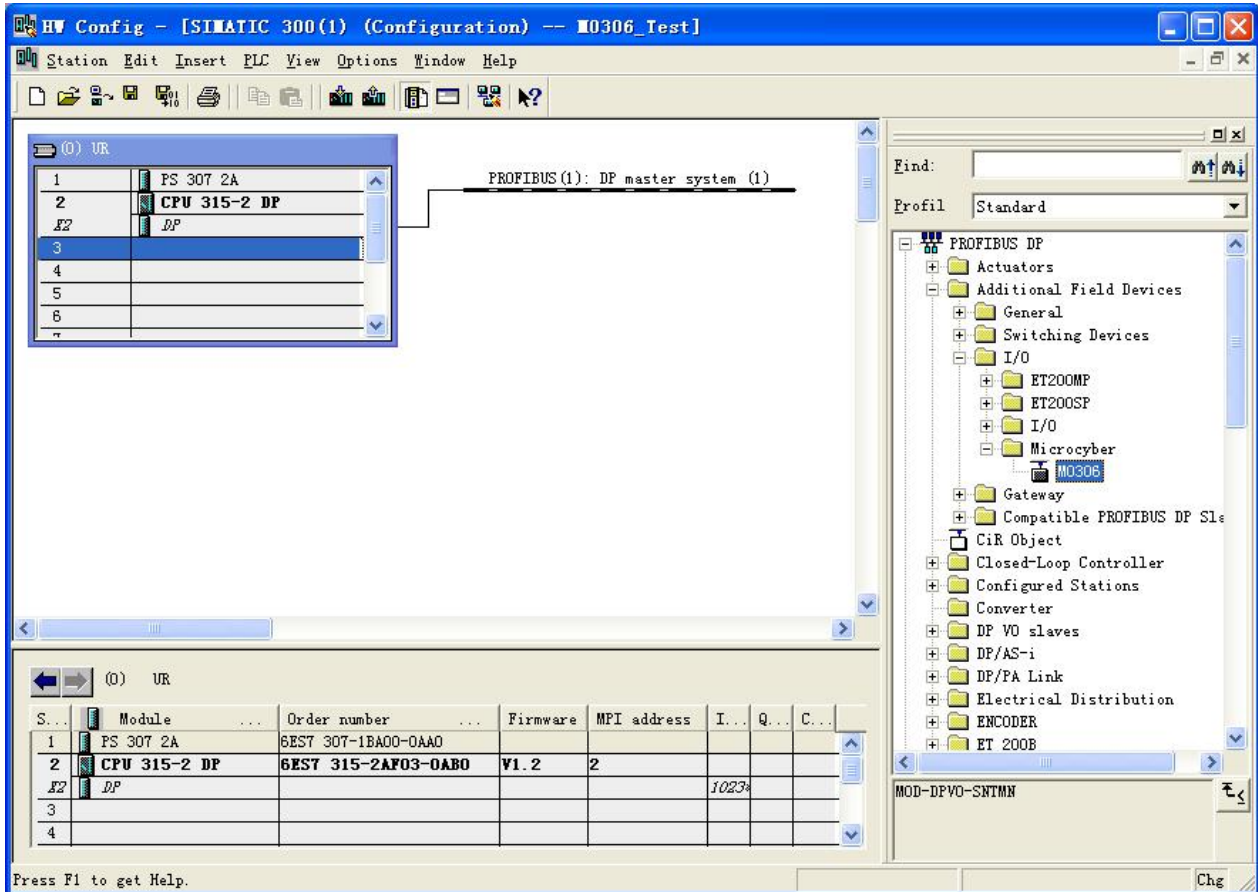

Figure 4.3 Correctly Installed Devices

- 2) Drag gateway to DP bus, and it will show the properties window automatically. Here shall the user configure the requested address, and we choose address 7, as shown in figure Figure 4.4:



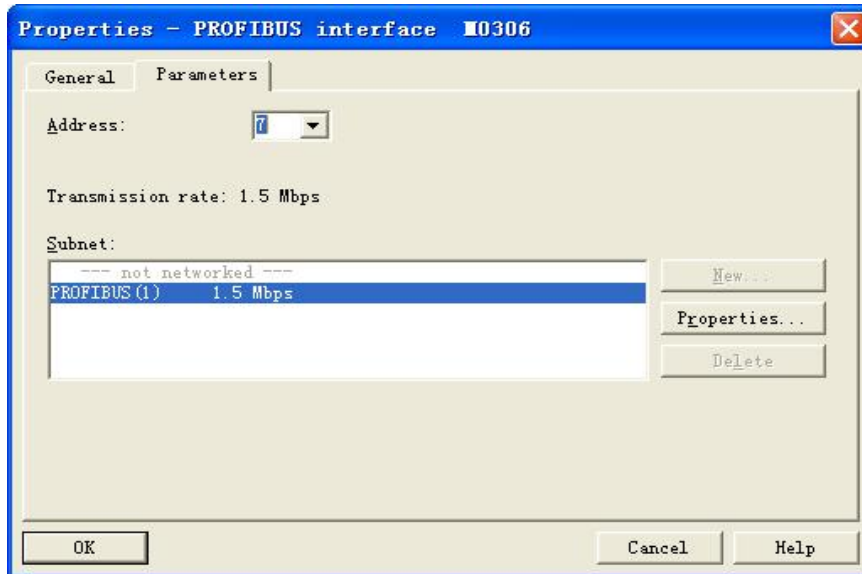

Figure 4.4 Device Properties Configuration

- 3) Click "OK" to finish adding the module.
- 4) Click M0306 module icon (device icon) in the configuration image, the device's I/O module configuration information shall be shown in the left bottom side of the window, which is analyzed from GSD file's I/O configuration identifier, as shown in figureFigure 4.5:

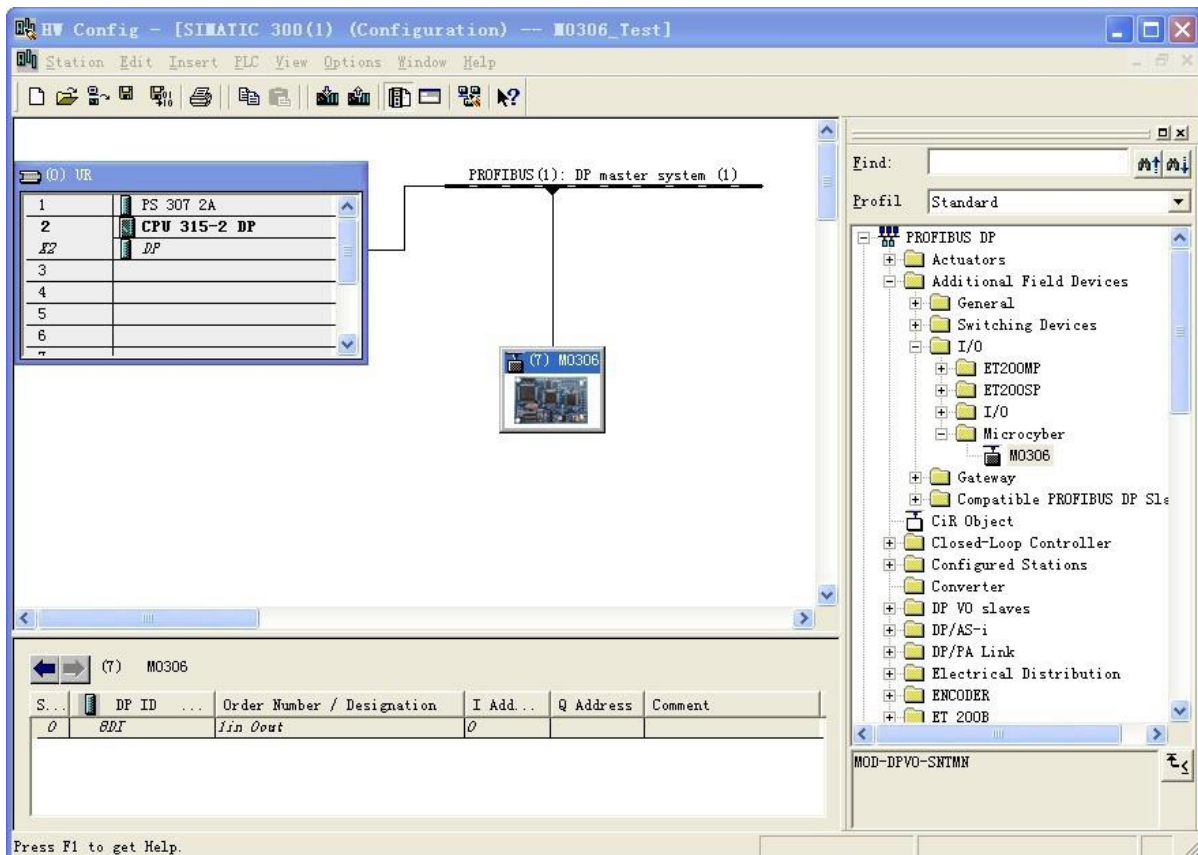



Figure 4.5 Device Configuration

## Chapter 5 ABNORMAL MODBUS COMMUNICATION

In normal working mode, M0306 module is master in Modbus terminal, used for cyclic Modbus read and write data communication with the user board. When Modbus communication fails, M0306 module can indicate it through LED2. At the same time, module reports system communication failure diagnosis information to PROFIBUS master station, and with the information, abnormal Modbus command and abnormal code can be located.

When there's communication failure between M0306 and user board, M0306 will report first detected Modbus command communication failure to master control system through diagnostic messages and real-time update the Modbus command communication failure code. If there's other Modbus command communication failure at the same time, M0306 will not report them. Only when the first reported one is solved, it will solve the next one, until no communication failure.

### 5.1 Device Online Monitoring

Click device online monitoring button , then device step into online monitoring status, as shown in figure Figure 5.1:

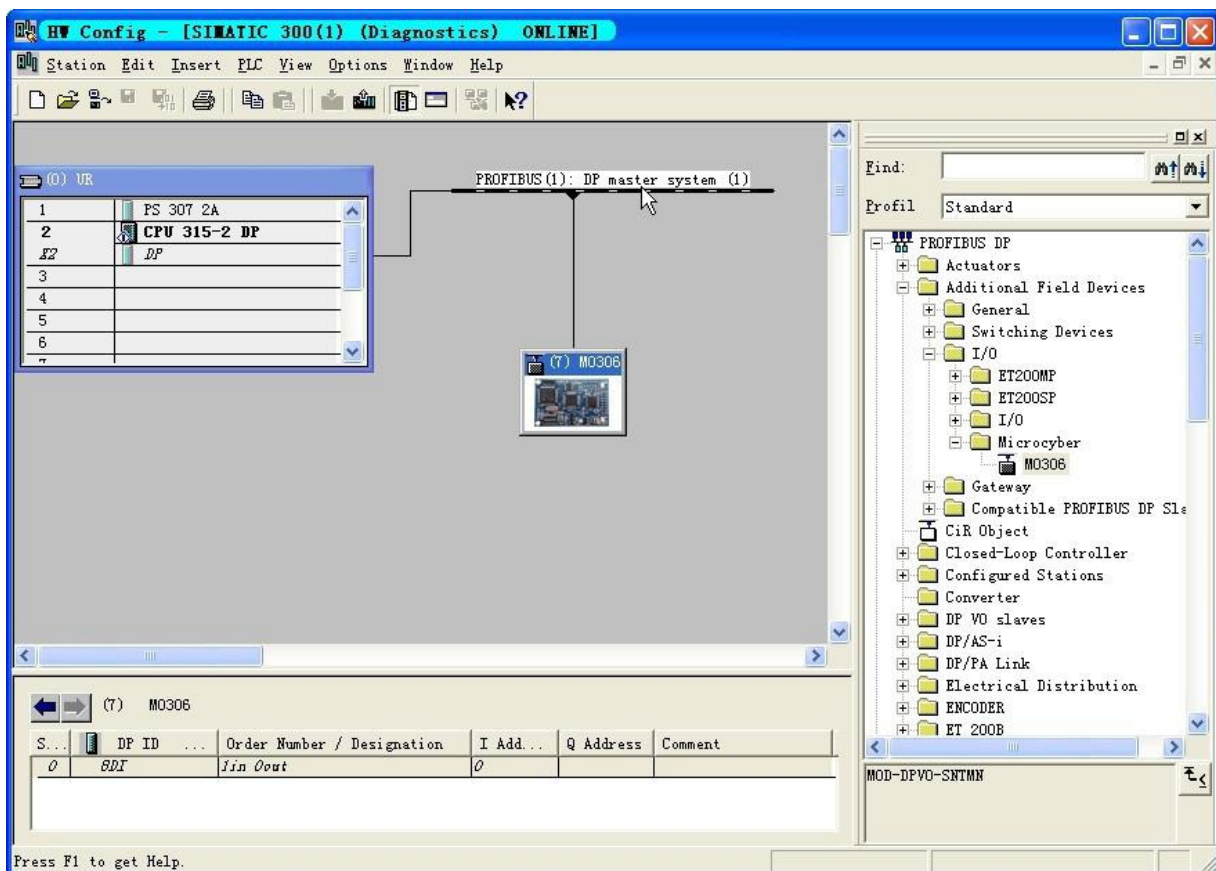

Figure 5.1 Device ONLINE Status

## 5.2 Monitoring Module Information

Right click M0306 module, choose “Module Information”, as shown in figureFigure 5.2:

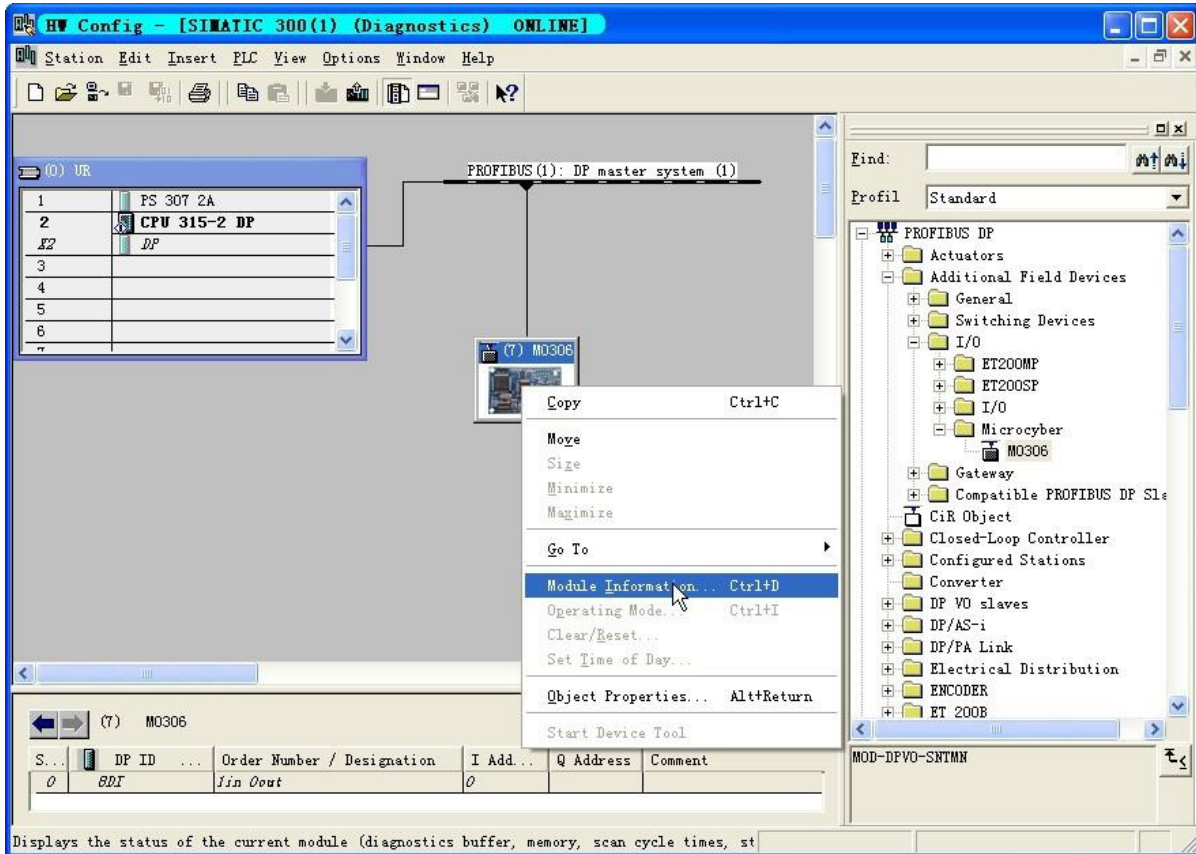

Figure 5.2 module monitoring

Click it and you will see the module monitoring dialog box, as shown in figure Figure 5.3:

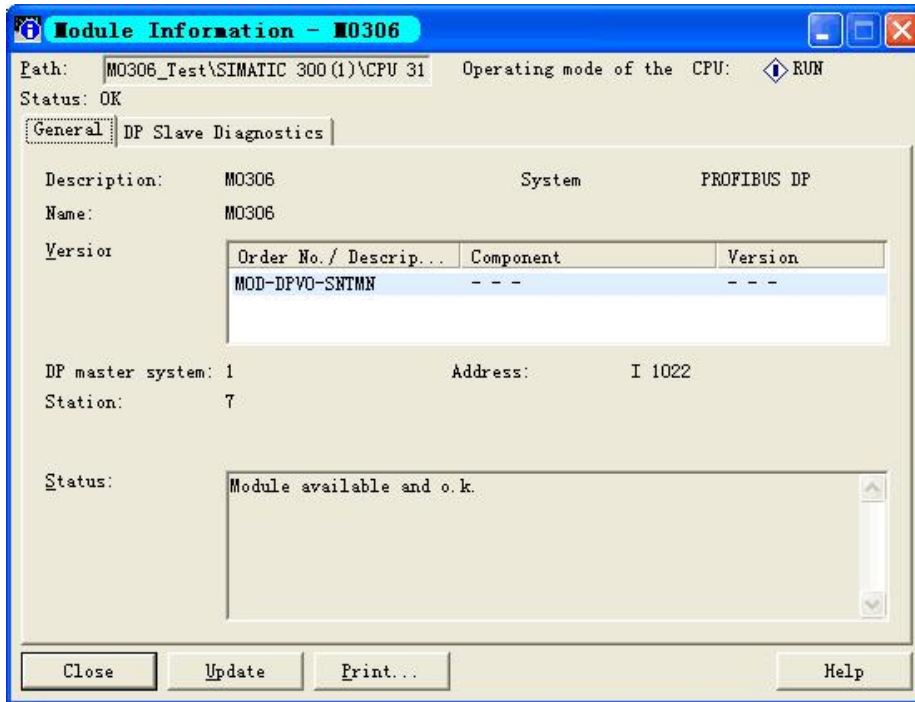

Figure 5.3 module monitoring dialog box

### 5.3 DP Slave Diagnosis

Choose “DP Slave Diagnostics” to display DP slave diagnosis information, as shown in figure Figure 5.4:

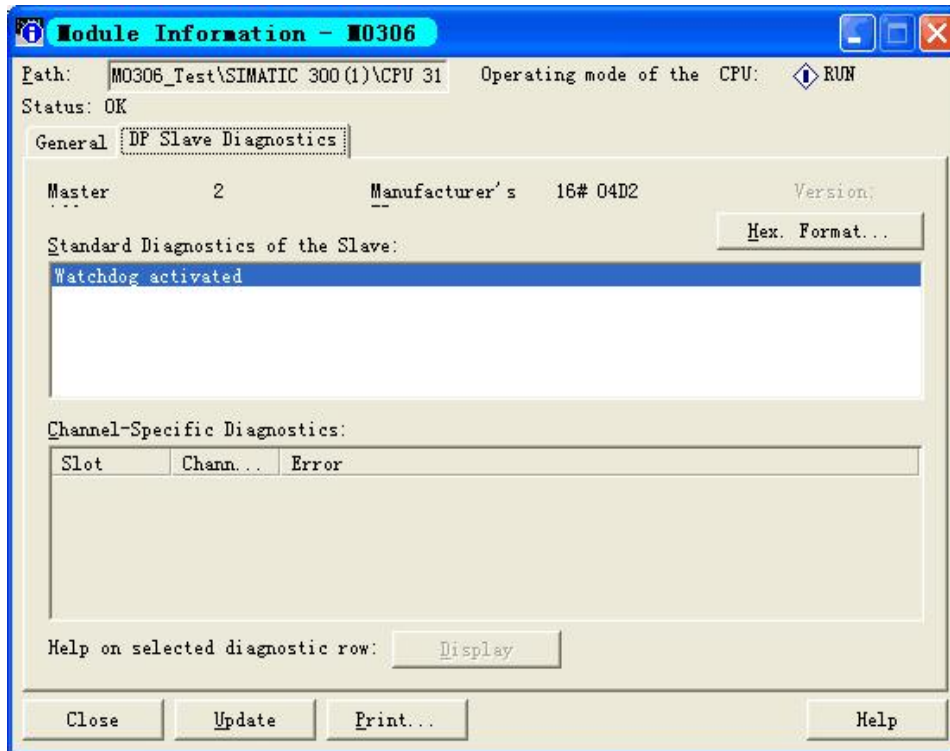

Figure 5.4 Module State OK

When Modbus communication is abnormal, the slave station diagnosis information is shown as figure Figure 5.5:

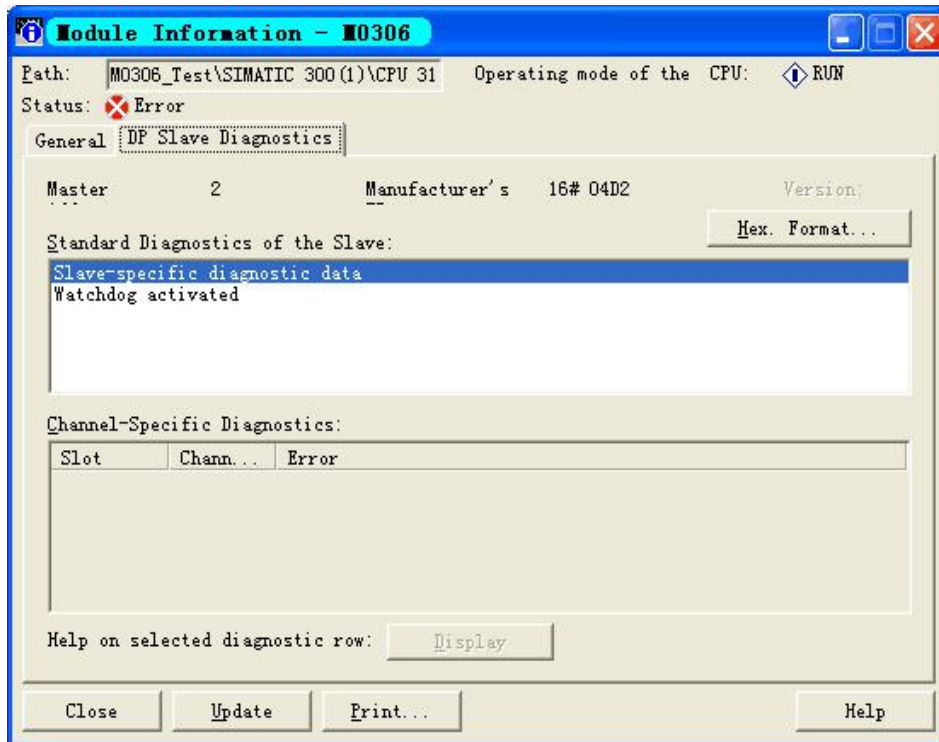

Figure 5.5 Module State Error

## 5.4 Diagnosis Information Analysis

When there's error during module communication, please select slave special diagnosis data item in column "Standard Diagnostics of the Slave" and click "Hex. Format..." button. Then user will see detailed diagnosis information as shown in Figure 5.6:

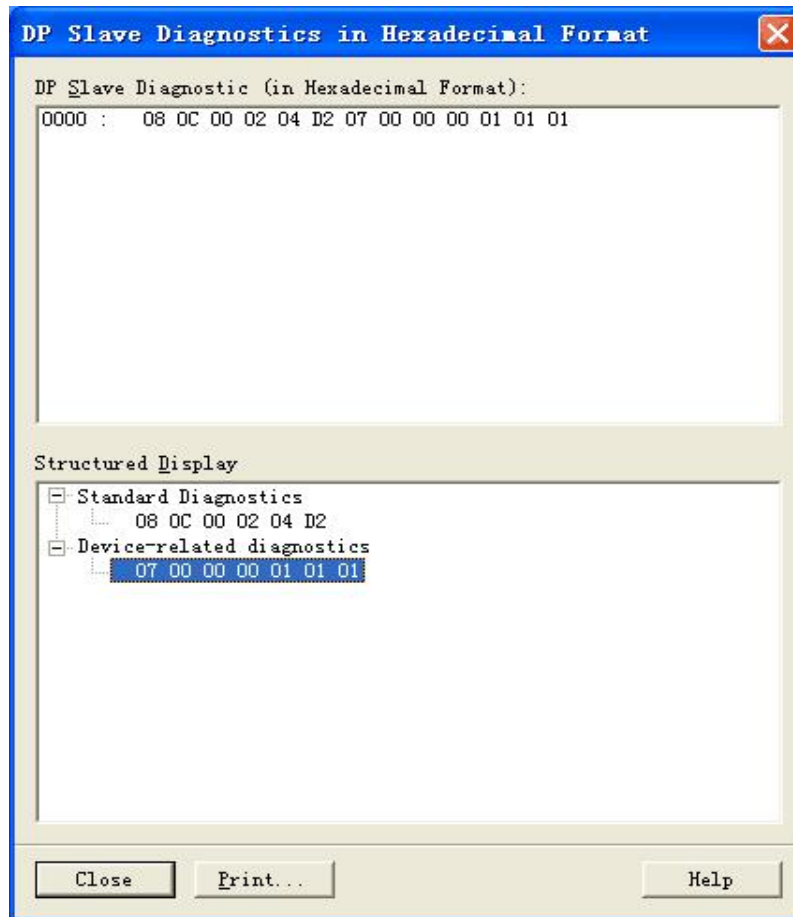

Figure 5.6 Module Diagnosis Message Information

Diagnosis message meaning is explained in Figure 5.7:

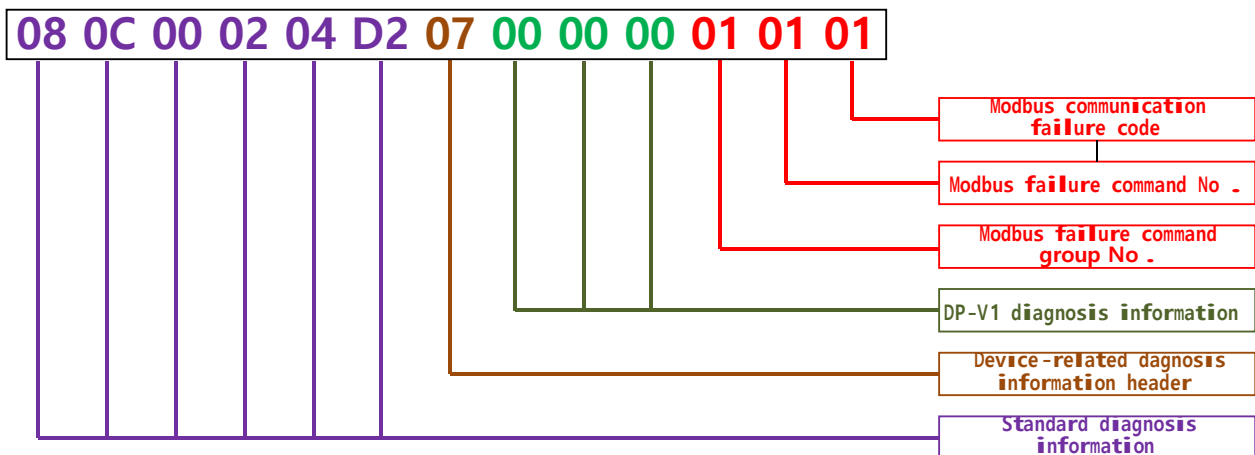

Figure 5.7 Diagnosis Information Analysis

- Standard diagnosis information  
PROFIBUS DP slave standard 6 bytes diagnosis information, no necessary to pay attention to it.
- Device-related diagnosis information header  
Special diagnosis information header byte, no necessary to pay attention to it.





■ DP-V1 diagnosis information

DP-V1 dedicated diagnosis information 3 bytes (reserved, not used) .

■ Modbus communication failure diagnosis information (3 bytes)

- Modbus abnormal command group no.

Command group no. for Modbus command with abnormal communication, as shown in table

Table 5.1:

Table 5.1 Modbus Command Group

Group no.	Meaning
0x00	set user parameter command group
0x01	read coil command group
0x02	read register command group
0x03	write coil command group
0x04	write register command group

- Modbus abnormal command no.

Group inner no. of Modbus command with abnormal communication (N≤0x14) is shown in table Table 5.2:

Table 5.2 Group Inner No. of Modbus Command With Abnormal Communication

No.	Meaning
0x01	the first abnormal Modbus command communication
0x02	the second abnormal Modbus command communication
...	...
N	the N abnormal Modbus command communication

- Modbus communication failure code

Modbus command failure code with communication failure is shown in table Table 5.3:

Table 5.3 Modbus Communication Failure Code

Failure code	Name	Meaning
0x01	Illegal function	For slave device, the function code received from the query is inadmissible operation.
0x02	Illegal data address	For slave device, the data address is received from the query is inadmissible address.
0x03	Illegal data value	For slave device, the value included in query is inadmissible value.
0x04	Slave station device failure	Error, which cannot regain, happens when the device is trying to perform the requested operation.
0x05	Confirm	The request is received by slave device, and the request is being processed. But it takes a long time to process these operations.
0x06	Slave station busy	Slave device is processing the program commands with long duration.
0xFD	Serial check error	For the module, the response data received from the query has serial check error.
0xFE	CRC check error	For the module, the response data received from the query has CRC check error.



0xFF	No response of slave device	For the module, when there's query from the device, respond data timeout.
------	-----------------------------	---

Notice : Abnormal codes 0x01~0x06 in table above are Modbus standard abnormal code, and 0xFD 、 0xFE 、 0xFF are module internal defined abnormal code. During M0306 module and the user board actual Modbus communication processing, when communication error occurs, M0306 will sent the abnormal code value returned from user board to the PROFIBUS master system through user diagnosis function. Thus, self-definition of abnormal code is possible for user.



## Chapter 6 GSD FILE, ID CERTIFICATION TEST

### 6.1 GSD file、ID and certification test

#### 6.1.1 GSD file ( Electronic Data Sheet )

- 1) Each PROFIBUS slave the station or primary master station has a device description file, called GSD file. This file is used to describe the characteristics of the PROFIBUS device.
- 2) The GSD file contains all device defined parameters, including:
  - ✓ baud rate supported;
  - ✓ message length supported;
  - ✓ input / output data quantity;
  - ✓ meaning of diagnostic information;
  - ✓ optional module type etc..
- 3) GSD file is a text file that can be edited by Notepad software.
- 4) No matter what kind of system environment is used, device need configuring according to the GSD file.
- 5) International organization PROFIBUS PI provides GSD file editing software: GSD-Editor. The software can format in accordance with the technical standard of Profibus, checking the format of user's GSD file. The software's "help" is rich in content, which is a fast learning GSD file technology way. User must become members of the PI organization to download it.

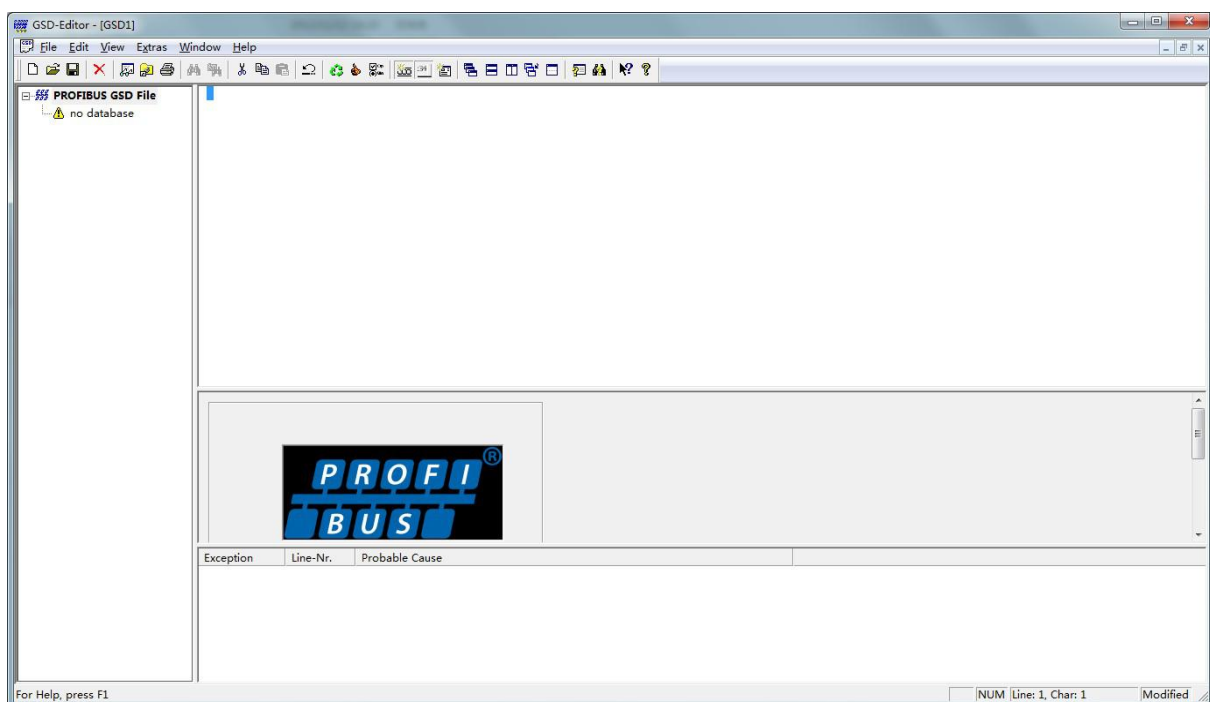

Figure 6.1 GSD-Editor open an empty file



## 6.1.2 ID ( Ident Number )

1) Each PROFIBUS device should have a unique ID number. The user can delegate "Chinese PROFIBUS CPA" to apply product ID from the international PROFIBUS organization PI.

2) Each membership can also apply manufacturer ID, non-members shall not apply that.

CPA Tel: 010-63405107

Contact: Wang Jing

CPA web <http://www.pi-china.org/>

## 6.1.3 Certification Test

1) The PROFIBUS test certification is not mandatory. However, if the product pass certification test, the design institute can give more confidence to end-users, which can also facilitate the products involved in the project bidding and market development.

2) Product testing can be conducted by Chinese PROFIBUS CPA. After the test, it can be entrusted to apply PI certification from the international PROFIBUS organization PI.

CPA Tel: 010-63322089

Contact: Liu Dan

CPA web <http://www.pi-china.org/>

## 6.2 User product GSD File and ID

1) Since this module is sold in OEM mode, the users have independent intellectual property and brand of the PROFIBUS device developed with this module. Thus, users' products cannot use module ID module and GSD file name.

2) Based on this module, Users can replace the company name, product type, serial number etc. to users' products information to have their own GSD file.

3) The GSD file is named according to the following rules, consisting of 8 strings, 4 high representative manufacturers, and low 4 representative ID. For example: "MCYB" in "MCYB0FC5.gsd" file is the abbreviation of "Microcyber", and "0FC5" is device ID. High 4 manufacturer name abbreviation is generally defined by the users themselves when filling the form during application of ID.

4) It can be connected only when module ID is the same with GSD files ID.



## Chapter 7 MAINTENANCE

- Simple maintenance

Table 7.1 Configuration Mode

LED	color	Normal	Abnormal	Reason	Solution
DP communication (LED1)	Red	On	Off	Slave device failure	Check slave connection and power
				Internal failure	Contact technical support
Modbus communication (LED2)	Green	Flicker 3 times Then always on	Off	Slave device failure	Check slave connection and power
				Internal failure	Contact technical support

Table 7.2 Normal Working Mode

LED	Color	Normal	Abnormal	Reason	Solution
DP communication (LED1)	Red	Off	On	No communication DP	Check DP master and DP interface device
				Power failure	Check power and connection



Modbus communication (LED2)	Green	On	Off	Internal failure	Contact technical support
				Slave disconnected	Connect with slave correctly
				Slave device failure	Check slave and connection
			Even flicker	Internal failure	Contact technical support
				DP slave address illegal	Check the validity of S1 or serial port set address
			No even flicker	User parameter configure invalid	Check whether the data configuration identifier parameter is valid
				Modbus communication abnormal	Check slave diagnostic message

- Daily maintenance is only for device cleansing.
- Failure maintenance: Please return to factory if there is failure.



# Chapter 8 TECHNICAL SPECIFICATION

## 8.1 Basic Parameter

Power	VCC (MCU power) : 5.0V 120mA / 3.3V 100mA
DP bus baud rate	Baud rate self- adaption: 9.6K~12Mbps
Protocol before transition	Modbus GB/Z 19582.1-2004
Protocol after transition	Profibus DP GB/T 20540.1~.6-2006
DP max input data	Max Input Bytes $\leq$ 244 Bytes
DP max output data	Max Output Bytes $\leq$ 244 Bytes
DP max total input and output data	Input Bytes + Output Bytes $\leq$ 360 Bytes
max user data	Max User Data Bytes $\leq$ 200 Bytes
Max IO configuration data	Max IO Configuration Data Bytes $\leq$ 20 Bytes
Temperature range	-40°C ~ +85°C
Humidity range	5 ~ 95%RH
Start time	$\leq$ 5s
Weight	14 g
Dimension (L×W×H)	65×42×14 mm
Electromagnetic compatibility	GB/T 18268.1
Noise interference	EN 61131-2:2003

## 8.2 Support Modbus Function Code

01H	read coil state
02H	read input state
03H	Read holding register
04H	Read input register
05H	Set single coil
06H	Preset single register
0FH	Force various coils
10H	Preset various registers



## Appendix 1 GSD File Example

```
-----  
; GSD Detail For Microcyber IO Slave  
; Date: 2016-03-15  
; File: MCYB0FC5.gsd  
; Microcyber,Hu Donghua  
-----
```

```
#Profibus_DP  
GSD_Revision=5  
Vendor_Name= "Microcyber"  
Model_Name= "M0306"  
Revision="V1.0"  
Ident_Number= 0x0FC5  
Protocol_Ident=0  
Station_Type=0  
Hardware_Release="V1.0"  
Software_Release="V1.0"  
9.6_supp=1  
19.2_supp=1  
93.75_supp=1  
187.5_supp=1  
500_supp=1  
45.45_supp=1  
1.5M_supp=1  
3M_supp=1  
6M_supp=1  
12M_supp=1  
MaxTsd_r_9.6=60  
MaxTsd_r_19.2=60  
MaxTsd_r_45.45=250  
MaxTsd_r_93.75=60  
MaxTsd_r_187.5=60  
MaxTsd_r_500=100  
MaxTsd_r_1.5M=150  
MaxTsd_r_3M=250  
MaxTsd_r_6M=450  
MaxTsd_r_12M=800  
Implementation_Type="APC3"  
Bitmap_Device= "MCYB0FC5"  
  
OrderNumber="MOD-DPV0-SNTMN"  
Freeze_Mode_supp=1  
Sync_Mode_supp=1  
Auto_Baud_supp=1  
Fail_safe=0  
Min_Slave_Intervall=1
```



Max\_Diag\_Data\_Len=13  
Modular\_Station = 0  
Max\_Module=1  
Max\_Input\_Len=244  
Max\_Output\_Len=244  
Max\_Data\_Len=360

Max\_User\_Prm\_Data\_Len=3  
Ext\_User\_Prm\_Data\_Const(0)=0x00,0x00,0x00

Modul\_Offset=0  
Slave\_Family=3@Microcyber

Module="1in 0out" 0x10  
1  
EndModule



## Appendix 2 Model Selection

MOD-DPV0		M0306 Modbus to DP embedded module									
		<b>Code</b>	<b>Master-slave</b>								
		S	Slave								
		<b>Code</b>	<b>Module type</b>								
		N	Normal								
		<b>Code</b>	<b>Hardware interface</b>								
		T	TTL								
		<b>Code</b>	<b>Software interface</b>								
		M	Modbus RTU								
		<b>Code</b>	<b>Module bus interface</b>								
		N	No bus interface								
		<b>Code</b>	<b>User interface 2 connector</b>								
		N	No								
		Y	Yes								
		<b>Code</b>	<b>MCU power supply</b>								
		33	3.3V								
		50	5.0V								
MOD-DPV0	-	S	N	T	M	N	-	N	33	model	example





# MICROCYBER

## YOUR FIELDBUS EXPERT

### CONTACT INFORMATION

**Address:** 17-8 Wensu Street, Hunnan New District, Shenyang, China

**Website:** [www.microcyber-fieldbus.com](http://www.microcyber-fieldbus.com)

**Phone:** +86-24-31217278/+86-24-31217280

**Fax:** +86-24-31217338

**Email:** [fang.siqi@microcyber.cn](mailto:fang.siqi@microcyber.cn)